

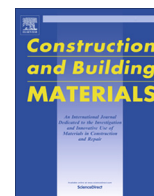

Contents lists available at ScienceDirect

# Construction and Building Materials

journal homepage: [www.elsevier.com/locate/conbuildmat](http://www.elsevier.com/locate/conbuildmat)

## Flexural characteristics of lightweight ferrocement beams with various types of core materials and mesh reinforcement

Ibrahim G. Shaaban<sup>a,\*</sup>, Yousry B. Shaheen<sup>b</sup>, Essam L. Elsayed<sup>c,1</sup>, Osama A. Kamal<sup>d</sup>, Peter A. Adesina<sup>e</sup><sup>a</sup> Civil and Industrial Engineering Dept., University of Liverpool On Sabbatical, Benha University, Egypt<sup>b</sup> Civil Engineering Dept., Menoufia University, Shebin Elkoum, Egypt<sup>c</sup> Benha University, Shoubra, Egypt<sup>d</sup> Civil Engineering Dept., Benha University, Shoubra, Egypt<sup>e</sup> Civil and Industrial Engineering Dept., University of Liverpool, UK

### HIGHLIGHTS

- The main objective is to studying the flexural behaviour of ferrocement beams with lightweight cores and types of mesh reinforcement.
- Cores were made of autoclaved aerated lightweight brick, extruded foam, and lightweight concrete cores; and are reinforced with expanded metal mesh, welded wire mesh and fibre glass mesh.
- Flexural behaviour including first crack loads and deflections, ultimate loads and deflections, ductility index, strain characteristics, crack pattern and failure mode were investigated.
- Effect of different types of core materials and mesh reinforcement on the flexural behaviour of studied beams was investigated.
- Ferrocement beams of light weight cores may be promising as an alternative to conventional beams especially for low cost residential buildings.

### ARTICLE INFO

#### Article history:

Received 30 November 2017

Received in revised form 9 March 2018

Accepted 21 March 2018

#### Keywords:

Ferrocement beams  
Lightweight  
Mesh types  
Core material types  
Ductility  
Deflection  
Concrete strains  
Flexural behaviour

### ABSTRACT

Sixteen reinforced concrete beams having the cross-sectional dimensions of  $100 \times 200 \times 2000$  mm and clear span of 1800 mm were cast and tested until failure under a single mid-span concentrated load. Ferrocement beams in this research contained either an Autoclaved Aerated lightweight brick Core (AAC), Extruded Foam Core (EFC), or a Lightweight Concrete Core (LWC); and were reinforced with either Expanded Metal Mesh (EMM), Welded Wire Mesh (WWM) or Fibre Glass Mesh (FGM). Structural behaviour of studied beams, including first crack, ultimate load, deflection, ductility index, strain characteristics, crack pattern and failure mode were investigated. Experimental work results showed that ferrocement beams exhibited higher ductility indices than those of the control normal and lightweight test beams to different degrees. Ferrocement beams made of EFC core generally gave the lowest ductility index while the highest ductility index was found for beams made of AAC and LWC cores. Ferrocement beams demonstrated better crack control and did not undergo spalling as opposed to the conventional beams. Specimens reinforced by EMM showed better ductility than those reinforced by WWM and even after increasing the reinforcement ratio of WWM, the situation did not change. Specimens reinforced by FGM had the lowest ductility compared to specimens reinforced by steel mesh. Cracks were found to develop more rapidly in beams reinforced by EMM, while beams reinforced by FGM exhibited the least amount of cracks. The results of this research showed that ferrocement beams of light weight cores may be promising as an alternative to conventional beams and may be viable alternatives especially for low cost residential buildings.

© 2018 The Authors. Published by Elsevier Ltd. This is an open access article under the CC BY license (<http://creativecommons.org/licenses/by/4.0/>).

## 1. Introduction

Cementitious composites including ferrocement are considered as construction materials with the potential of meeting the increasing demand for high performing, economical, sustainable and complex structures. The production and application of

\* Corresponding author.

E-mail addresses: [ibrahim.shaaban@liverpool.ac.uk](mailto:ibrahim.shaaban@liverpool.ac.uk) (I.G. Shaaban), [p.a.adesina@liverpool.ac.uk](mailto:p.a.adesina@liverpool.ac.uk) (P.A. Adesina).

<sup>1</sup> Now: Concrete and Bridges Testing, Industrial Private Sector, Canada.

cement-based composites is environment friendly as it consumes less embodied energy, making these materials one of the preferred sustainable construction alternatives. Various investigations into the physical and mechanical properties of ferrocement shows that it has excellent strength properties, crack control, impact resistance and toughness which gives it an advantage over other thin construction materials [1–8]. This was attributed to the close spacing and uniform distribution of reinforcement within the material. The short steel fibres added to ferrocement improve its cracking and stress-strain behaviour thereby making ferrocement a superior construction material [9]. Ferrocement affords the opportunity of producing relatively light prefabricated structural elements which can be made into interesting architectural forms for low cost housing. Ferrocement as a construction material has been used in silos, roofs, tanks and also in the construction and repair of reinforced concrete structures [10–12]. As an alternative to the conventional steel and wooden formwork, ferrocement laminates have also been utilized as permanent forms which eventually remain as part of structural elements such as beams and slabs as it is more cost-effective [13–16]. Ferrocement permanent formwork was found to offer great potential for speedy construction and material maximization at minimal cost, especially in curved structures. It also gives an advantage of reducing the required tensile reinforcement in beams and slabs as it incorporates steel meshes which contributes to the tensile capacity of the structural elements [17–19]. The effect of steel mesh type and the number of steel

mesh layers on the performance of the beams of U-shaped ferrocement formwork was investigated [19]. Results showed that these beams gave better performance in terms of high ultimate and serviceability loads, enhanced crack control, high ductility and improved energy absorption. Similar results were reported by Shaheen and Eltehawy [8] who investigated the effectiveness of U-shaped ferrocement forms reinforced with different types of reinforcement for the construction of reinforced concrete slabs.

Desayi and El-Kholy [20] studied the stress-strain characteristics of lightweight fibre reinforced ferrocement specimens in uniaxial tension. The study reported that due to fibre inclusion in the ferrocement specimens, failure was by a single major crack developed which indicates the fibre reinforced ferrocement tension members behave as if they are made of an 'homogenous' material as opposed to the behaviour of specimens made with ferrocement only. Studies conducted by El-Wafa and Fukuzawa [21], on the effect of wire mesh reinforcement on the tensile behaviour of ferrocement composite plates shows improvement in the service and ultimate tensile crack behaviour of the composite plates with failure occurring after sufficient warning. El-Wafa and Fukuzawa [22] investigated the characteristics of ferrocement thin composite elements with stainless steel and E-fiberglass meshes under flexure. Their variables were the effect of mesh type, number of mesh layers, mesh wires diameters with opening size and type of mortar material. They reported that stainless steel meshes resulted in improved bending behaviour as their crack pattern was in the form

**Table 1**  
Details of specimens.

| Group | Specimens Designation | Specimen's Core Configuration | Reinforcement details |                        |                   |               |                           |
|-------|-----------------------|-------------------------------|-----------------------|------------------------|-------------------|---------------|---------------------------|
|       |                       |                               | Tension Steel bars    | Compression Steel bars | Links             | No. of Layers | Type of Mesh              |
| A     | A1                    | .....                         | 2 $\phi$ 12           | 2 $\phi$ 10            | $\phi$ 6 @ 150 mm | .....         | .....                     |
|       | A2                    | .....                         | 2 $\phi$ 12           | 2 $\phi$ 10            | $\phi$ 6 @ 150 mm | .....         | .....                     |
| B     | B1                    | AAC                           | 2 $\phi$ 12           | 2 $\phi$ 10            | .....             | 1             | Expanded Metal Mesh (EMM) |
|       | B2                    | AAC                           | 2 $\phi$ 12           | 2 $\phi$ 10            | .....             | 2             | Expanded Metal Mesh (EMM) |
|       | B3                    | AAC                           | 2 $\phi$ 12           | 2 $\phi$ 10            | .....             | 2             | Welded Wire Mesh (WWM)    |
|       | B4                    | AAC                           | 2 $\phi$ 12           | 2 $\phi$ 10            | .....             | 4             | Welded Wire Mesh (WWM)    |
| G     | G1                    | EFC                           | 2 $\phi$ 12           | 2 $\phi$ 10            | .....             | 1             | Expanded Steel Mesh (EMM) |
|       | G2                    | EFC                           | 2 $\phi$ 12           | 2 $\phi$ 10            | .....             | 2             | Expanded Steel Mesh (EMM) |
|       | G3                    | EFC                           | 2 $\phi$ 12           | 2 $\phi$ 10            | .....             | 2             | Welded Wire Mesh (WWM)    |
|       | G4                    | EFC                           | 2 $\phi$ 12           | 2 $\phi$ 10            | .....             | 4             | Welded Wire Mesh (WWM)    |
| F     | F1                    | LWC                           | 2 $\phi$ 12           | 2 $\phi$ 10            | .....             | 1             | Expanded Steel Mesh (EMM) |
|       | F2                    | LWC                           | 2 $\phi$ 12           | 2 $\phi$ 10            | .....             | 2             | Expanded Steel Mesh (EMM) |
|       | F3                    | LWC                           | 2 $\phi$ 12           | 2 $\phi$ 10            | .....             | 2             | Welded Wire Mesh (WWM)    |
|       | F4                    | LWC                           | 2 $\phi$ 12           | 2 $\phi$ 10            | .....             | 4             | Welded Wire Mesh (WWM)    |
|       | F5                    | LWC                           | 2 $\phi$ 12           | 2 $\phi$ 10            | .....             | 3             | Fibre Glass Mesh (FGM)    |
|       | F6                    | LWC                           | 2 $\phi$ 12           | 2 $\phi$ 10            | .....             | 6             | Fibre Glass Mesh (FGM)    |

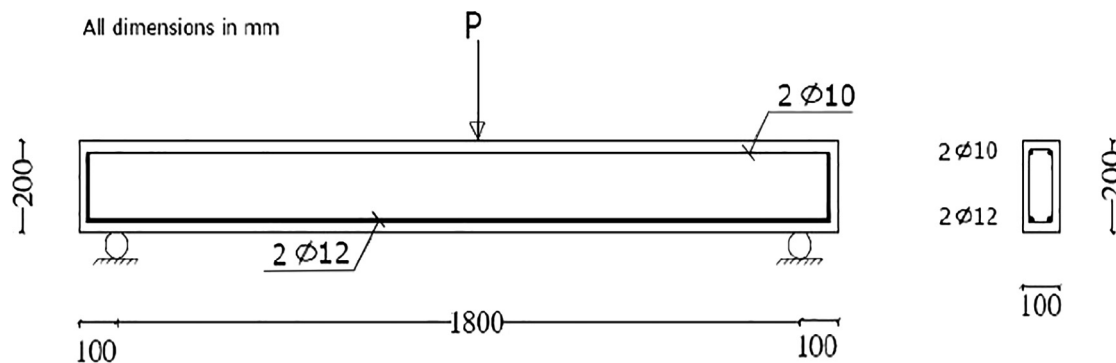

**Fig. 1.** Test specimens' dimensions.

of many fine and well-distributed cracks. On the other hand, they found that using fiberglass mesh for reinforcement resulted in structural elements of less cracks with wider widths and these elements can resist higher ultimate loads but showed less ductility than reinforcement by metal mesh. This was attributed to the higher Young's modulus of stainless steel meshes. Ferrocement

elements with stainless steel meshes were more ductile and failed in flexure with many fine cracks. Ferrocement elements reinforced by fibre glass mesh had a sudden flexural failure with a limited number of cracks and as a result deteriorated in ductility. Higher layer of reinforcement was reported to yield numerous well-distributed fine cracks.

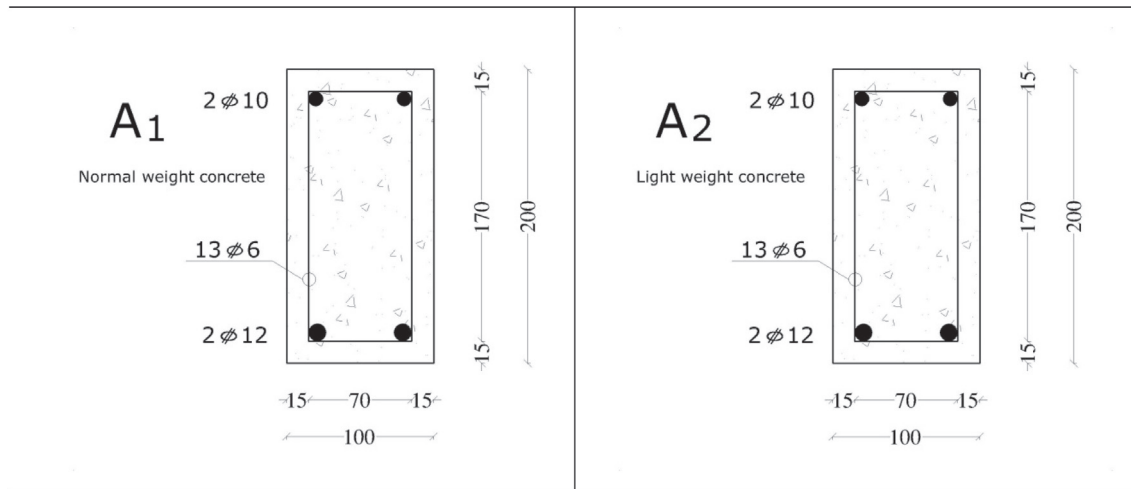

(a) Control beams A1 and A2

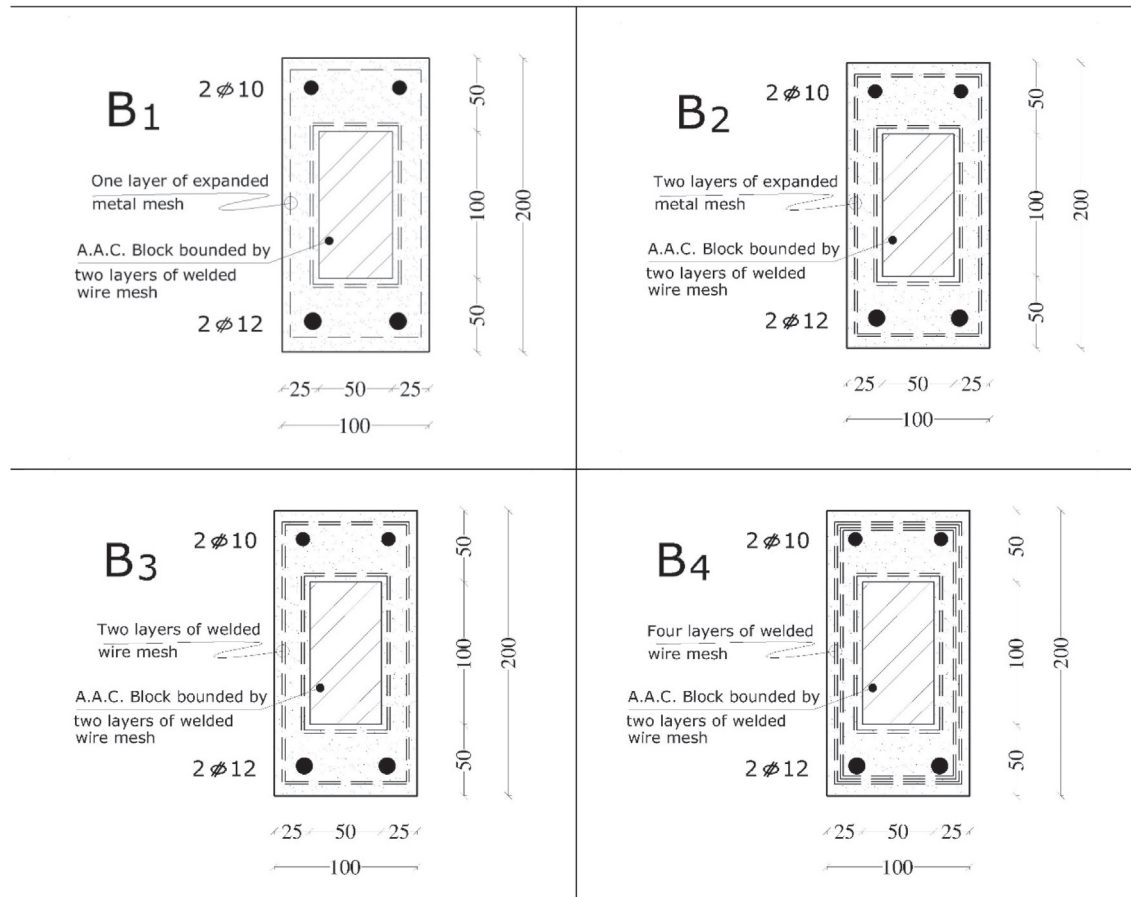

(b) Group B

Fig. 2. Typical cross sections of test specimens.

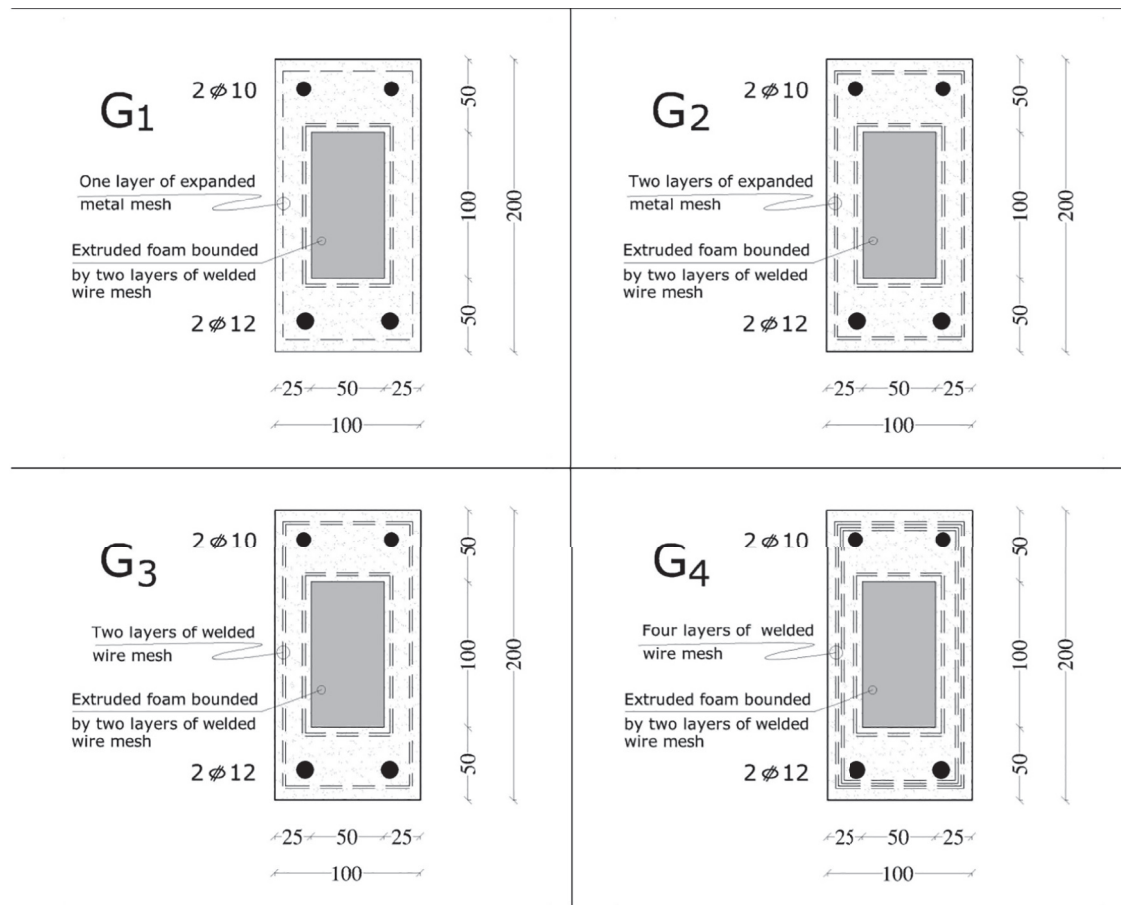

(c) Group G

Fig. 2 (continued)

Memon et al. [23] investigated the potential use of lightweight aerated concrete encased in ferrocement matrix for lightweight structural applications. Ferrocement encased lightweight aerated concrete sandwich walls were prepared to study characteristics such as flexural strength, failure mode, load-deflection behaviour and load-strain behaviour. Findings from the research support the potential application of ferrocement encased lightweight aerated concrete for lightweight structural elements. The failure mode of the ferrocement elements reflects the transformation of pure brittle characteristics of aerated concrete into ductile behaviour due to the ferrocement encasement. The behaviour of ferrocement under combined bending and axial loads was studied by Mansur and Paramasivam [24]. They found that for specimens in direct tension and those under combined bending and axial tension, the first crack was initiated at an early stage of loading. More cracks occurred across the entire width of the specimens as loading continued until a point was reached when one of the cracks opened continuously and increased in width at the expense of other cracks until eventual failure. For those in pure bending, numerous cracks appeared on the tensile face of the specimens and no crushing was observed in the compression zone even at a large curvature beyond the ultimate load. The number of cracks was found to generally increase with increasing amount of reinforcement. As the development of lightweight, cost effective and sustainable housing is increasingly being demanded and research into ferrocement as an alternative construction material to meet this demand is gaining more significance [25],

there is a need to add to or increase the scope of existing research literature on flexural behaviour of ferrocement beams.

## 2. Research objective

This research is the first phase of a larger research focused at investigating the effect of different types of core materials, different types and amount of mesh reinforcement on the structural behaviour of lightweight ferrocement composite beams. In this paper, the structural indicators, namely, first crack load, ultimate load, deflection at first crack load, deflection at ultimate load, and ductility index were recorded. Load-deflection and load-tensile strain relations were used in the evaluation of the studied test beams. The specimens used in this research were full scale specimens in order to understand the actual behaviour of lightweight ferrocement composite beams. In addition, crack patterns and failure modes of the studied beams were not only observed and recorded but they were also linked and explained by the structural indicators, load-deflections and load strains relationships.

## 3. Experimental program

Sixteen simply supported composite beams classified into four different groups (A, B, G and F) and of the same cross sectional dimensions of  $100 \times 200 \times 2000$  mm and a span of 1800 mm were

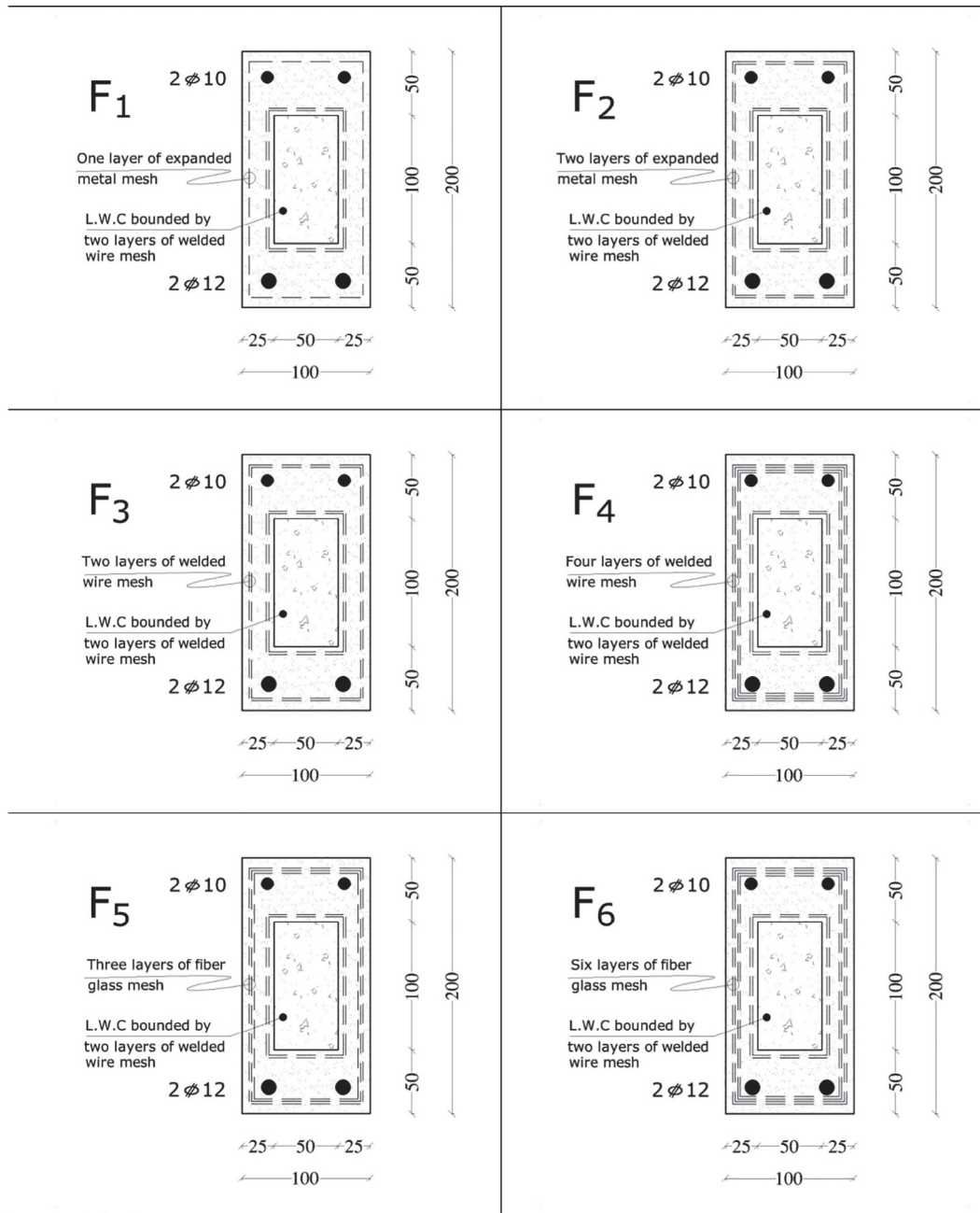

(d) Group F

Fig. 2 (continued)

**Table 2**  
Geometric and physical properties of the steel meshes.

| Mesh type | Mesh opening (mm) |           | Dimension of strands (mm) |           | Diameter (mm) | Grid size (mm) | Weight (kg/m <sup>2</sup> ) | Proof strength (MPa) |
|-----------|-------------------|-----------|---------------------------|-----------|---------------|----------------|-----------------------------|----------------------|
|           | Long way          | Short way | Width                     | Thickness |               |                |                             |                      |
| WWM       | .....             | .....     | .....                     | .....     | 0.60          | 12 * 12        | 0.422                       | 400-600ult           |
| EMM       | 32.0              | 14.00     | 3.00                      | 1.00      | .....         | .....          | 1.355                       | 280-350ult           |

cast and tested until failure under a single concentrated load at midspan. Table 1 summarises details of the test specimens. Beams A1 and A2 which represent conventional concrete beams forms

Group A, A1 was cast as normal weight concrete beam while A2 was cast as lightweight concrete beam. Beams in Group B were made of reinforced autoclaved aerated lightweight brick core



(AAC); Group G beams were made of reinforced extruded foam core (EFC); Group F beams were made of reinforced lightweight concrete core (LWC). Typical test beam dimensions and reinforcement is shown in Fig. 1. Fig. 2 shows the cross-section details of the beams.

### 3.1. Materials

- **Aggregate:** The fine aggregate used in this research was of natural siliceous sand passing a No. 4 sieve (4.75 mm), clean and free of any deleterious substances, and of fineness modulus 2.867. The aggregate was graded in conformity to the guide for design of ferrocement elements [26]. The normal weight coarse aggregate used was crushed dolomite with maximum nominal

aggregate size of 19 mm. Autoclaved light weight brick manually crushed to a suitable size of maximum nominal size 10 mm forms the lightweight coarse aggregate used.

- **Cement** used was Ordinary Portland cement of grade 42.5 and in compliance with Type I Portland cement [27].
- **Water** used was clean drinking water free from substances harmful to cement hydration and durability of concrete, and suitable for concrete mixing.
- **Super plasticizer** used complies with ASTM C 494/C494M, [28] and of density 1.21 kg/litre at room temperature. The superplasticizer was used in two dosages. The normal dosage used for higher workability without water reduction makes up 0.15–0.30% of cement weight (about 0.50–1 kg/m<sup>3</sup> of concrete).

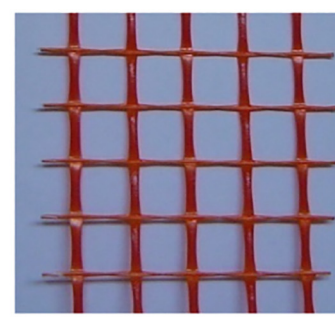
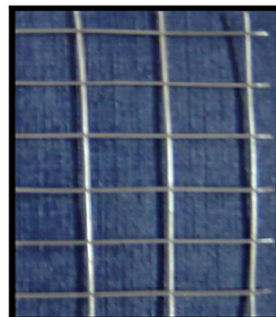
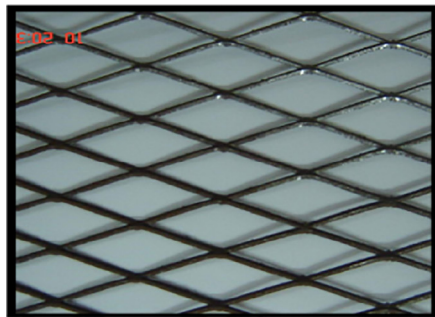

(a) Expanded metal lath sample (b) Welded wire mesh sample (c) Fibre glass mesh sample



(d) Polypropylene Fibres PP 300-e3

Fig. 3. Different types of meshes used for reinforcement.

Table 3

Proportions by weight of normal weight concrete mix.

| Material                    | Cement | Silica fume | Water | Coarse aggregate | Fine aggregate | Superplasticizer |
|-----------------------------|--------|-------------|-------|------------------|----------------|------------------|
| Weight (kg/m <sup>3</sup> ) | 315    | 35          | 140   | 1200             | 720            | 3.50             |

Table 4

Proportions by weight of lightweight concrete mix.

| Material                    | Cement | Silica fume | Water | Crushed brick | Fine aggregate | Superplasticizer | P,P Fibre |
|-----------------------------|--------|-------------|-------|---------------|----------------|------------------|-----------|
| Weight (kg/m <sup>3</sup> ) | 405    | 45          | 171   | 420           | 701            | 9                | 1.50      |

Table 5

Proportions by weight of ferrocement mortar mix.

| Material                    | Cement | Silica fume | Water  | Fine aggregate | Superplasticizer | P,P Fibre |
|-----------------------------|--------|-------------|--------|----------------|------------------|-----------|
| Weight (kg/m <sup>3</sup> ) | 626.40 | 69.60       | 243.60 | 1392.00        | 10.44            | 1.50      |

- *Pozzolanic material* used as replacement ratio of cement in order to obtain high strength mortar is 10% cement replaced condensed silica fume. The chosen replacement percentage is based on literature results [29].
- *Reinforcing Steel* used for the reinforcement of test specimens were high tensile deformed bars (nominal yield strength, 360 N/mm<sup>2</sup>) of diameter 10 and 12 mm. For the control beams, mild steel stirrups of diameter 6 mm (nominal yield strength, 240 N/mm<sup>2</sup>) were used as shear reinforcement.
- *Mesh Reinforcement*
  - Square Welded Wire steel Mesh (WWM) and Expanded Metal Mesh (EMM) available in local markets forms the reinforcement for the ferrocement caging. The properties of the

meshes are as given in Table 2. The photographic views of the steel meshes are presented in Fig. 3.

- Fibre Glass Mesh (FGM) with opening dimension of 12 × 12 mm and 1.66 × 0.66 mm fibre string cross section dimension (longitudinal and transverse direction) was used in the research. The mesh has a weight of 123 gm/m<sup>2</sup>. Fig. 3 shows a sample of the FGM.
- *Polypropylene Fibre (PF)* used for the ferrocement mixes was one hundred percent virgin homopolymer polypropylene fibrillated fibres containing no reprocessed olefin materials (Fibermesh300-e3, micro-reinforcement system for concrete). Dosage of 1500 gm/m<sup>3</sup> was used. Fig. 3-d shows Polypropylene Fibre.

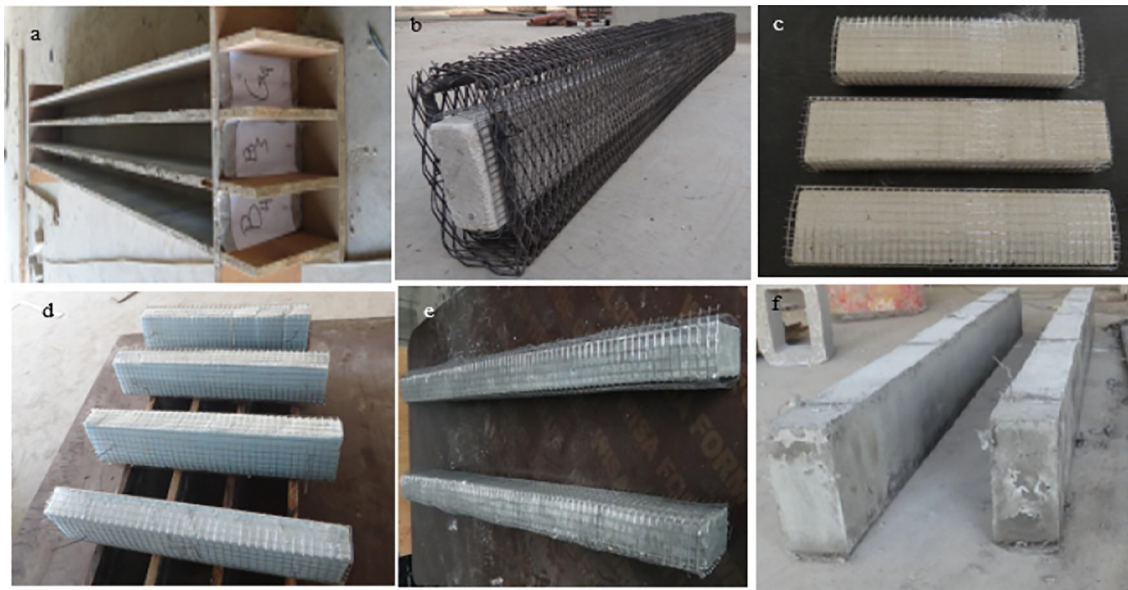

Fig. 4. (a) Wooden mould assembly (b) Main steel mesh caging (c) AAC core wrapped in double layers of welded mesh (d) EF core wrapped in double layers of welded mesh (e) LWC wrapped in double layers of welded mesh (f) Demoulded beam.

Table 6  
Relative weight of specimens after curing.

| Specimen Designation           | A1    | A2   | B1   | B2   | B3   | B4   | G1   | G2   | G3   | G4   | F1   | F2   | F3   | F4   | F5   | F6   |
|--------------------------------|-------|------|------|------|------|------|------|------|------|------|------|------|------|------|------|------|
| Wt. after curing (kg)          | 103.8 | 80.4 | 84.0 | 86.4 | 83.7 | 87.5 | 74.0 | 75.0 | 73.7 | 79.2 | 94.0 | 92.3 | 92.1 | 94.4 | 90.0 | 89.2 |
| % Wt. reduction relative to A1 | ..... | 22.5 | 19.1 | 16.8 | 19.4 | 15.7 | 28.7 | 27.7 | 29.0 | 23.7 | 9.4  | 11.1 | 11.3 | 9.1  | 13.3 | 14.1 |

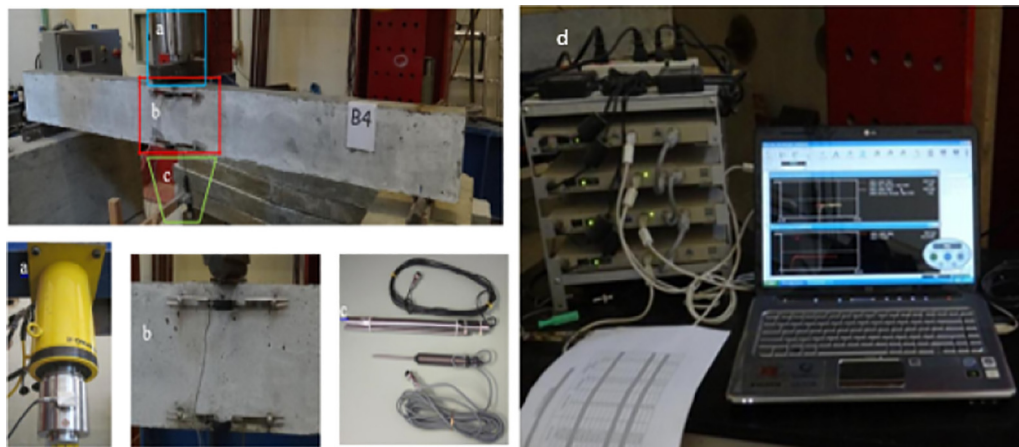

Fig. 5. Test specimen set up: (a) Hydraulic jack (b) Strain Gauges set up (c) LVDT (d) DAQ.

- AAC was used as the core material for Group B beams. It is commercially produced brick of dimensions  $600 \times 200 \times 100\text{mm}$ . The published technical data of this type of brick shows that it has dry unit weight of  $600\text{--}650 \text{ kg/m}^3$ , porosity of  $22\text{--}30\%$ , and thermal conductivity (K) of  $0.27\text{--}0.34 \text{ W/m}^\circ\text{C}$ .
- EFC was used as the core material for group G test beams. It is blue board ( $1.25 \times 0.6 \text{ m}$ ) manufactured through a continuous extrusion process, and with unique properties such as low thermal conductivity, high resistance to water penetration, high compressive strength and density of  $40 \text{ kg/m}^3$ .

3.2. Concrete and mortar matrix

The mix proportions by weight per cubic metre for the normal weight concrete, used for specimen, A1, and lightweight concrete, used for specimen A2 and Group F beams, are presented in Tables 3 and 4. The ferrocement beams were made of mortar produced in accordance to ACI 549.1R-93 & ACI 549-1R-88, [26]. The mix proportion for the mortar was as presented in Table 5. For the mortar mixes which required inclusion of PF, the fibre was added gradually to prevent the threads from clinging together (agglomeration).

Table 7  
Test results for studied specimens' groups.

| Group | Specimens Designation | First crack load, kN | Ultimate load, kN | Deflection at first crack load, mm | Deflection at ultimate load, mm | Ductility index |
|-------|-----------------------|----------------------|-------------------|------------------------------------|---------------------------------|-----------------|
| A     | A1                    | 30.86                | 35.76             | 5.56                               | 18.80                           | 3.38            |
|       | A2                    | 30.11                | 32.56             | 7.32                               | 50.15                           | 6.85            |
| B     | B1                    | 30.20                | 37.77             | 6.21                               | 65.31                           | 10.52           |
|       | B2                    | 29.75                | 40.98             | 5.49                               | 64.40                           | 11.72           |
|       | B3                    | 38.52                | 44.14             | 6.61                               | 30.32                           | 4.58            |
|       | B4                    | 39.80                | 46.19             | 7.22                               | 30.32                           | 4.20            |
| G     | G1                    | 30.79                | 39.82             | 6.82                               | 54.53                           | 8.00            |
|       | G2                    | 30.26                | 37.19             | 7.12                               | 25.94                           | 3.64            |
|       | G3                    | 31.17                | 38.50             | 7.83                               | 41.91                           | 5.35            |
|       | G4                    | 32.51                | 36.73             | 7.43                               | 24.42                           | 3.29            |
| F     | F1                    | 31.09                | 40.95             | 5.60                               | 67.96                           | 12.15           |
|       | F2                    | 30.13                | 38.75             | 5.90                               | 18.82                           | 3.19            |
|       | F3                    | 31.59                | 37.08             | 6.21                               | 22.28                           | 3.59            |
|       | F4                    | 35.98                | 39.87             | 7.32                               | 42.12                           | 5.75            |
|       | F5                    | 30.60                | 37.67             | 5.90                               | 25.43                           | 4.31            |
|       | F6                    | 35.96                | 40.13             | 6.00                               | 11.80                           | 1.97            |

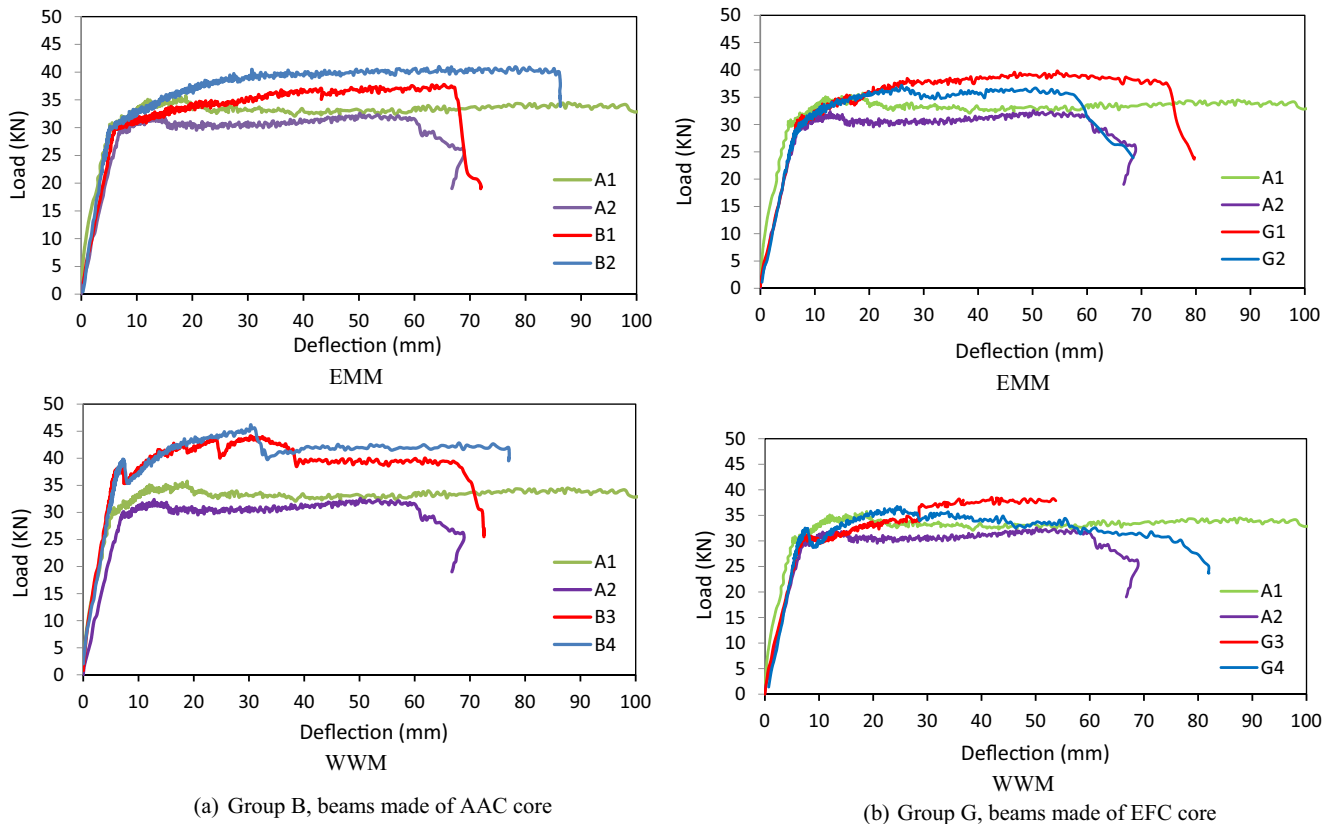

Fig. 6. Load-deflection relationships of different groups of test beams.



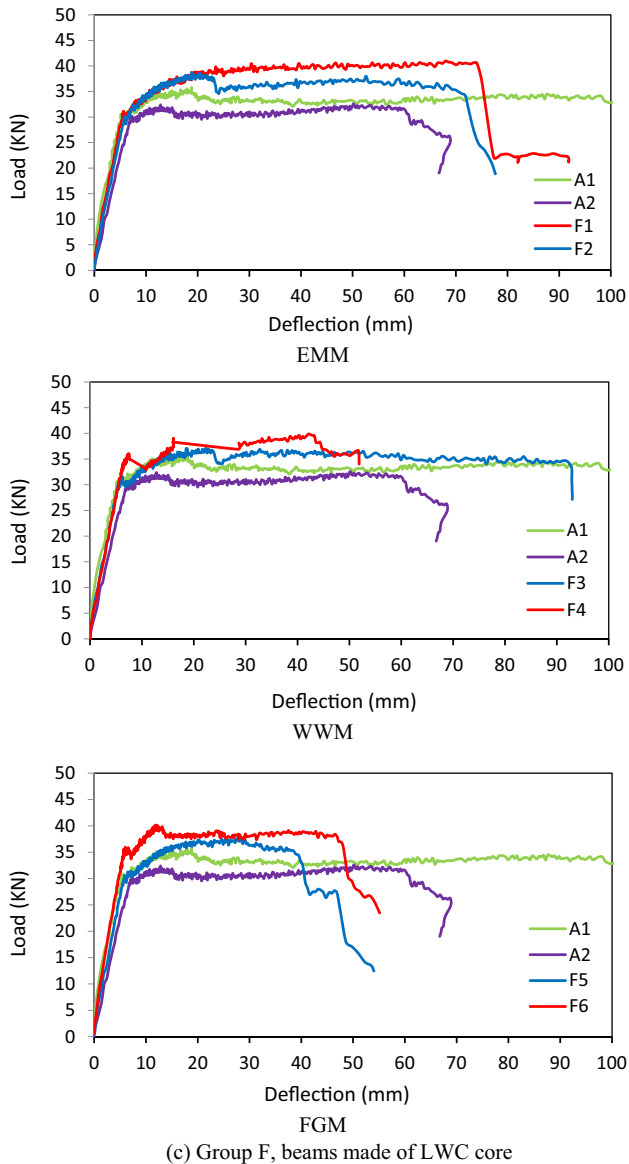

Fig. 6 (continued)

The required amount of superplasticizer was added to mortar mixes to improve workability. In order to ascertain the strength property of the mixes, three cubes of dimensions  $150 \times 150 \times 150$  mm were cast each for control concrete beams A1 and A2 while three cubes of dimensions  $50 \times 50 \times 50$  mm were cast from the mortar mixes. For the normal weight, A1, and lightweight, A2, control beams, the compressive strengths were 40 and 24 MPa, respectively. For the mortar used in preparing the ferrocement beams, the compressive strength of the different batches ranged between 35 and 36 MPa.

### 3.3. Preparation of test specimen

A wooden mould, designed to effectively cast three test specimens simultaneously, was used for casting the specimens. Fig. 4 shows the mould, the main wire mesh caging, the ferrocement cores wrapped with WWM and the demoulded beam. To cast the beams, the wooden mould was assembled and a thin film of shuttering oil was applied, reinforcement caging was then placed in the mould. For the ferrocement beams, mortar was first placed and

vibrated in the mould to a thickness of 50 mm before introducing reinforcement caging with cured spacers forced into the mortar layer to provide adequate cover for the steel wire mesh. After placing the caging in the mould, the concrete for the control beams or mortar matrix for ferrocement beams were then poured and vibrated using electrical vibrator to ensure proper compaction and eliminate any air voids. The beams were covered in a polyethylene sheet for 48 h, thereafter demoulded, and wrapped in wet burlap for 28 days to allow curing. At 28 days, the specimens were weighed and then stored in a cool and dry place till testing. The weights of the test specimens after curing were recorded in Table 6. It can be seen from the table that comparing the conventional normal weight concrete beam with those made of light weight cores showed an average weight reduction of 17.7%, 27.3% and 22.5% for AAC, EFC and LWC, respectively.

### 3.4. Test setup

All beams were tested under three lines loadings. Linear Variable Displacement Transducer (LVDT) placed at mid span of test beam was used to monitor deflection at the point of load application. Two strain gauges placed at 2 cm away from top and bottom edges of the test beam at mid span were used to measure concrete compressive and tensile strains (see Fig. 5). The beams were painted using white emulsion so that crack patterns could be easily observed. To start the test, the specimens were placed in the loading frame in the correct position. A small load was then first applied to make sure that all instruments were working. The load was thereafter increased gradually till the failure of the specimen. At each load stage, strains in concrete and the deflections were recorded automatically using a computerized data acquisition (DAQ) system. The crack pattern was also noted at each load stages. The ultimate load was identified when excessive cracking occurred at the bottom of the beam, applied load dropped and deflection increased according to El-Wafa and Fukuzawa [22].

## 4. Experimental results and discussions

Structural characteristics investigated included first crack load, ultimate load, deflection at first crack load, deflection at ultimate load, ductility index, concrete tensile strains, crack pattern, and failure mode. In addition, the load–deflection curves and load–tensile strain curves of the studied specimens were drawn. The deflection at first crack load on the curve is the deflection at the first crack initiation which is the point at which the curve begins to deviate from the initial linear relationship. Ductility index is the ratio of the deflection at ultimate loads to that at the first crack. Higher ductility index value indicates that a beam allows for more warnings before ultimate collapse. Table 7 records the above mentioned values, Figs. 6 and 7 show the load–deflections and load–tensile strain relationships for studied beams.

### 4.1. Load-deflection relationships

Fig. 6a–d show the load–deflection relationships for studied beams. Each figure shows the relationships for a group of beams with one type of core material and reinforced by one type of mesh reinforcement at different ratios compared to the control normal weight and lightweight concrete beams. It can be seen from Fig. 6a–d that, generally, different types of core materials, different types and amount of mesh reinforcement affect the structural responses of studied beams to different degrees. It was also observed from Table 7 that, generally, specimens of higher deflection at first crack load eventually had lower deflection at failure and consequently lower ductility index. Table 7 and Fig. 6 show

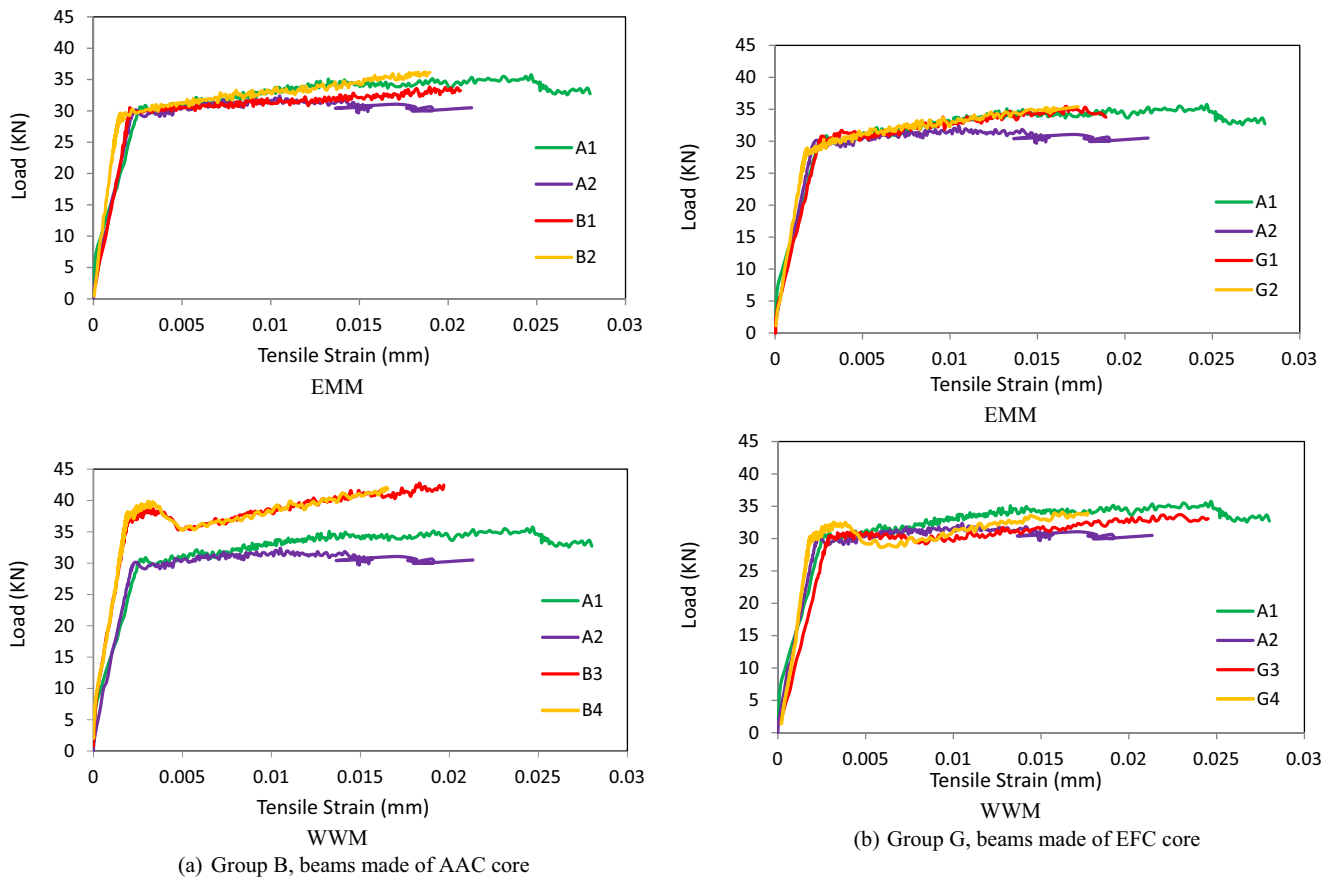

Fig. 7. Load-tensile strain relationships for different groups of test beams.

that the ultimate loads of ferrocement beams were higher than that of the normal concrete control specimen, A1 and light weight control one, A2, by a range of 6–42% while the ultimate load of Specimen A1 was higher than that of Specimen A2 by 10% only. This may be attributed to the fact that the stiffness of Specimen A1 is higher than that of the lightweight specimen, A2 while the addition of mesh reinforcement layers to the ferrocement composite beams increased both of the stiffness and ductility. This is in agreement with the results reported by Shaheen and Eltehavy [8]. It can be noticed also that the deflection at ultimate load and ductility index values of most of ferrocement beams were higher than that of Specimen A1. By studying Table 7 it can be seen that most of ferrocement beams have first crack loads slightly higher than that of the control beams. The deflections at first crack loads were higher than that of the conventional concrete control specimen, A1, and lower than that of the lightweight concrete control specimen, A2. Increasing the amount of mesh reinforcement to two or more layers resulted in further improvement of the behaviour of Group B (beams with AAC core material) (see Fig. 6a) and Group F (beams with LWC core materials) (see Fig. 6c). This is in agreement with previous publications which reported that the increase in number of mesh reinforcement layers resulted in higher ultimate loads and higher ductility index [22,30–31].

Fig. 6a and Table 7 show that, for Group B of AAC cores, beams B1 and B2 reinforced by one and two layers of EMM had lower first crack load, higher ultimate load, higher deflection at ultimate load and consequently higher ductility index values compared with those of B3 and B4 reinforced by two layers and four layers of WWM. This may be attributed to the lower yield strength and higher flexibility in EMM compared to that of WWM. These find-

ings were also reported by Wasim and Razvi [32]. For the beams reinforced by EMM, higher reinforcement layers resulted in higher ductility while the opposite was noticed for beams reinforced with WWM. Fig. 6b and Table 7 showed the same trend for Group G, which has beams with EFC cores, but to a less degree. The values recorded in Table 7 and Fig. 6b show that Group G, beams with EFC core materials, generally had the lowest ductility index values compared to the other groups. This can be attributed to the fact that EFC had the lowest density and strength compared to the other core types as indicated above in Section 3.3. Fig. 6c and Table 7 show that Beams F5 and F6 in Group F specimens, which has LWC core material, had the lowest ductility in the group despite that its ultimate load was high. This is in agreement with Shaaban and Seoud [33] who reported that using FGM mesh reinforcement for structural elements lead to higher ultimate load and lower ductility compared to steel mesh reinforcement. Fig. 6 and Table 7 show also that the increase of the number of mesh layers did not necessarily result in increasing the ductility in all specimens. The observed effect depends on an additional factor which is the core type which may interfere with the significance of amount of mesh reinforcement on ductility.

#### 4.2. Load-tensile strain curves

Fig. 7 shows the load-tensile strain curves of the test specimens. The tensile concrete strains at ultimate loads for control beams A1 and A2 were found to be 0.0279 and 0.0213, respectively. Beam A1 allows for more tensile concrete strains before ultimate collapse when compared to beam A2. This may be attributed to the high load carrying capacity of beam A1 made of normal-weight concrete

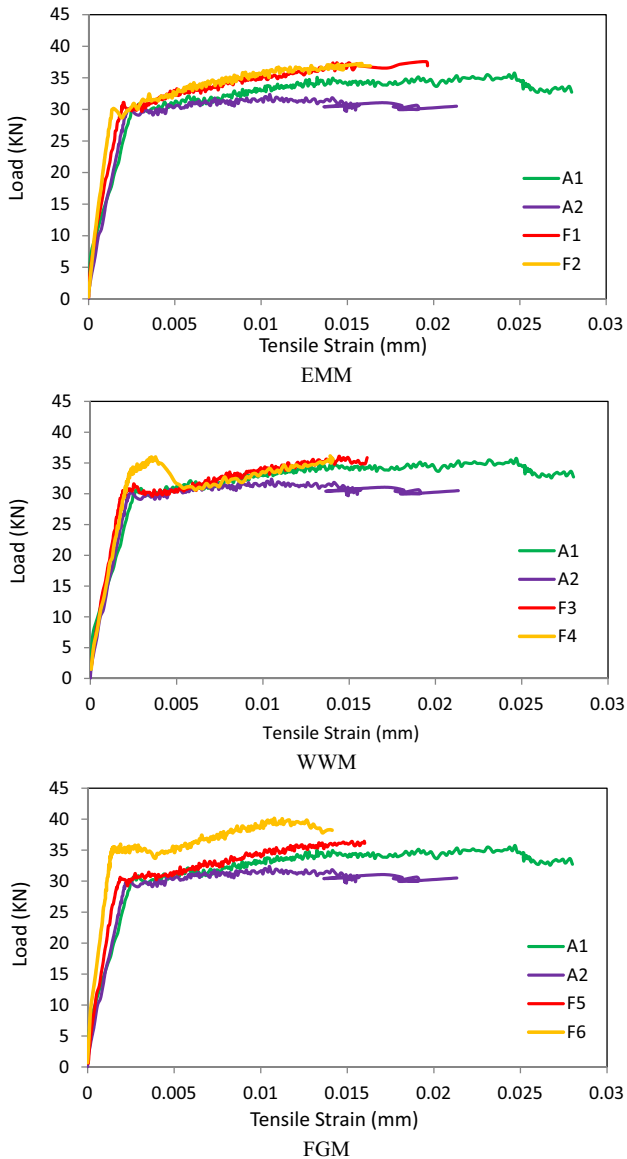

(c) Group F, beams made of LWC core

Fig. 7 (continued)

compared to beam A2 made of lightweight concrete. Fig. 7 a-c show that the ferrocement beams have higher ultimate loads compared to the control beams to different degrees depending on the types of mesh reinforcement and core material used in the ferrocement beams. It should be noted that once the cracks were developed in the beams, the crack width was included in the measured strain. The strain after cracking in the beams was affected by the location of cracks in the beams. This will be explained in detail in the next section and it is in agreement with what was reported by El-Wafa and Fukuzawa [34]. In addition, Fig. 7a-c show that the load-tensile concrete strains of the beams were characterised by a linear relationship at early load stages but thereafter changed to a non-linear response. This is also in agreement with the findings of El-Wafa and Fukuzawa [22].

Fig. 7a shows that the tensile concrete strain at failure for ferrocement beams, B1 to B4, were 0.0249, 0.0189, 0.0196, and 0.0167, respectively. Beam B1 exhibited the highest tensile concrete strains while beam B4 had the least concrete strains. It was observed that the failure tensile concrete strain of the beams was

not commensurate to their load carrying capacity and this may be attributed to the fact that the concrete strain included the crack widths which varied from one beam to another. This explains the findings of the previous section where B4, reinforced by WWM, had the maximum ultimate load but a lower ductility index. This is in agreement with the findings of Fahmy et al. [19] who reported that WWM reinforcement has higher ultimate load but less ductility compared to EMM reinforcement. Fig. 7b shows that the tensile concrete strain at failure for ferrocement beams, G1 to G4, were found to be 0.0189, 0.0173, 0.0245, and 0.0176, respectively. The tensile strain of the beams in this group was found to be more fairly commensurate with their load carrying capacity unlike beams in Group B. Based on the limited number of specimens, it seems that this may be attributed to the effect of core type since it is the governing factor which differentiates between beams in Fig. 7a and those in Fig. 7b. It can be seen from Fig. 7c that the tensile concrete strain at ultimate loads for ferrocement beams, F1 to F6, were found to be 0.0196, 0.0163, 0.016, 0.0139, 0.016 and 0.0140, respectively. Beam F1, reinforced by EMM, was found to allow the highest tensile concrete strains while beams F4, reinforced by WWM, and F6, reinforced by FGM, had the least concrete tensile strain. This is in agreement with what reported by researchers in literature that the EMM reinforcement has higher ductility than that of WWM and FGM reinforcement [14,26].

#### 4.3. Crack pattern and failure mechanism of beams

##### 4.3.1. Control specimens (Group A)

Fig. 8a shows the crack pattern of control specimens A1 and A2. For control beams A1 and A2, hair cracks were observed to develop first at the bottom edge of the beam's mid span. However, the number of hair cracks in the control beams was limited and the cracks were wider in width and more spaced compared to those of ferrocement beams with EMM which had numerous finer hair cracks as shown in Fig. 8b-d. Upon increasing the load, the cracks propagated rapidly upwards and number of cracks increased along the span. The length and width of the cracks increased with increasing the applied load. Spalling of concrete was also observed in the beam. Although that the control beams showed similar behaviour, Beam A2 developed finer cracks with smaller width compared with that of Beam A1. The control beams failed by spalling of the concrete at the surface, by cracking and by crushing of the concrete which is in agreement with findings of Fahmy et al., [19]. While Specimen A1 spalled both at the top and the bottom, Specimen A2 underwent crushing at the top.

##### 4.3.2. AAC ferrocement beams (Group B)

Fig. 8b shows the crack pattern of AAC beams reinforced with EMM and WWM. It was found that flexural cracks developed from around the mid span at the bottom of the beams. The cracks were, however, less than those of the control specimens and this could be due to the higher reinforcement which controlled crack width in the ferrocement beams. It was observed that cracks were developed, in specimens reinforced with EMM, more rapidly than those reinforced with WWM. This is in agreement with the findings of Fahmy et al., [19] and may be attributed to the higher yield strength of WWM compared to EMM. It was observed also that ferrocement beams reinforced with WWM and made of AAC developed fewer cracks with greater widths than those in the conventional beams. This contradicts the findings of the other researchers who reported that ferrocement beams have numerous finer cracks width compared with that of conventional beams [19,24,30,31,34]. As was mentioned earlier for ductility, unlike findings from other researchers [24,35], it was observed that higher number of mesh reinforcement layers does not necessarily translate to numerous fine cracks. For example, Specimen B4

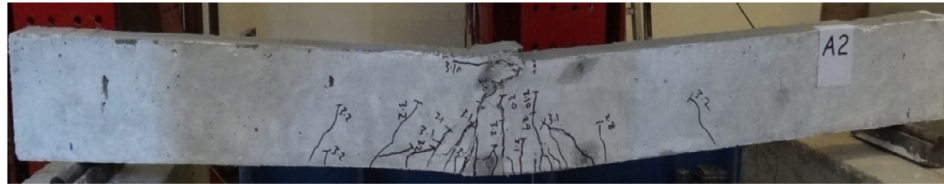
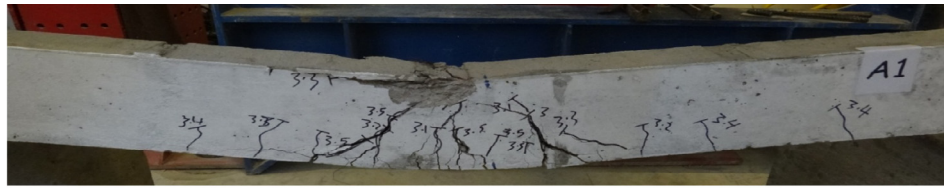

(a) Group A

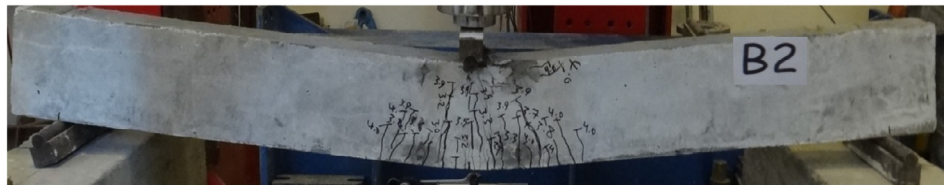

(b) Group B

Fig. 8. Crack pattern for different studied test beams.

reinforced with four layers of WWM showed less ductility than B1 reinforced by one layer of EMM (see Table 7). It may be argued that the different core types used in the studied beams affect the significance of mesh reinforcement on crack pattern and ductility. Failure of the beams in this group occurred only by cracking at the bottom, crushing at the top and no spalling was observed.

#### 4.3.3. EFC ferrocement beams (Group G)

Fig. 8c shows the crack pattern of EFC core beams reinforced with EMM and WWM. Again, it was observed that flexural cracks developed from around the mid span of the ferrocement beams

and the beams exhibited more crack control compared to the control beams. Beams reinforced with WWM showed less warnings prior to failure compared to those reinforced by EMM, which had more hair cracks but with less crack width. This is in agreement with the findings in the literature [19,34]. It can be argued that EMM is more flexible as it resulted in beams with less crack width and more ductility compared with WWM which allowed less cracks due to its higher yield strength but exhibited greater crack width and brittle failure. This supports the ductility index values in Table 7, load-deflection relations and load-strain relations shown in Figs. 6 and 7. Failure of the beams occurred only by





(c) Group G

Fig. 8 (continued)

cracking at the bottom and crushing at the top and no spalling was observed. Increasing the number of mesh layer reinforcement in the beams lead to reduction of the number of cracks. This supports findings from other researchers who reported that beams with higher number of finer cracks gave higher ductility [22,31,34,36].

#### 4.3.4. LWC core ferrocement beams (Group F)

Fig. 8d shows the crack pattern of LWC core beams reinforced with EMM, WWM and FGM. Beams reinforced with EMM had more number of cracks but with less crack widths than the other specimens in the group. As observed with the previous groups, beams reinforced with WWM resulted in a brittle failure, fewer cracks with wider crack widths compared with those reinforced with EMM. As also reported by Fahmy et al., [19], the cracks in the beams reinforced with WWM were almost vertical and spread along the whole depth of the beam. Beams reinforced with FGM had the lowest amount of cracks in the group but these cracks had wider widths. Similar observations were reported earlier by El-Wafa and Fukuzawa [22]. Crack patterns and failure modes in Fig. 8d are supported by the results indicated in Table 7 and the relationships drawn in Figs. 6 and 7. Again, failure of the beams occurred only by cracking at the bottom and crushing at the top.

## 5. Conclusions

The flexural behaviour of lightweight ferrocement composite beams under concentrated loads as compared to that of conventional structural reinforced concrete beams was the focus of this research's experimental program. The following conclusions can be drawn:

1. The behaviour of the ferrocement beams was highly influenced by the core type, the type, and amount of mesh reinforcement. Ferrocement beams made of EFC generally gave the lowest ductility index. This may be attributed to the fact that EFC has the lowest density and strength compared to other core types. The highest ductility indices were found in either beams made of AAC or LWC. All ferrocement beams generally gave a ductility index higher than that of normal weight control specimen except for specimens reinforced with FGM.
2. It was found that ferrocement beams with EMM generally gave higher ductility index than those with WWM. Increasing the number of mesh layers resulted in higher ultimate loads, however, ductility index was not always increased with the increase of mesh reinforcement amount. Beams with LWC cores and reinforced by FGM generally showed lower ductility compared to those reinforced by EMM and WWM reinforcement.
3. Ferrocement beams were found to show better crack control and less spalling compared to the conventional beams. This can be attributed to the higher reinforcement in form of mesh layers in the ferrocement beams which, in turn, controlled crack widths.
4. Ductility was found to be highly affected by type of mesh reinforcement. The effect of number of reinforcement layers on ductility was less pronounced. For example, specimens reinforced with WWM at higher reinforcement showed brittle fracture. Cracks were found to develop more rapidly in beams reinforced with EMM while beams reinforced with WWM and FGM developed fewer cracks with greater widths than those reinforced by EMM and those of conventional reinforcement.





(d) Group F

Fig. 8 (continued)

5. Based on the results of this study, ferrocement lightweight concrete beams reinforced by EMM can be a suitable alternative to the conventional reinforced concrete beams since adding EMM for lightweight beams improves the structural indicators such as cracking loads, ultimate loads and ductility of such beams compared to conventional lightweight concrete beams. Improvement of these structural indicators may lead to the production of ferrocement beams which can compete with conventional reinforced concrete beams in terms of both of cost and sustainability.

#### Conflict of interest

The authors declare that they have no conflict of interest.

#### Acknowledgement

A special acknowledgement is due to Eng. Waleed El Sayed, in charge of Materials Laboratory, American University in Cairo, for his help with conducting the experimental testing.

#### References

- [1] A.E. Naaman, *Ferrocement and Laminated Cementitious Composites*, Techno press 3000, Ann Arbor, Michigan, 2000.
- [2] R. Wrigley, *Permanent Formwork in Construction*, Construction Industry Research & Information Association (CIRIA), London, 2001.
- [3] E. Fahmy, Y. Shaheen, M. Abou Zeid, Development of ferrocement panels for floor and wall construction, 5th Structural Specialty Conference of the Canadian Society for Civil Engineering, Canada, 2004.

- [4] E.H. Fahmy, Y.B. Shaheen, Z.M.D. Abou, A.M. Gaafar, Ferrocement sandwich and hollow core panels for wall construction, *J. Ferrocement* 36 (3) (2006) 876–891.
- [5] E.H. Fahmy, Y.B. Shaheen, Z.M.D. Abou, A.M. Gaafar, Ferrocement sandwich and hollow core panels for floor construction, *Can. J. Civ. Eng.* 27 (1) (2012) 1297–1310.
- [6] Y. El-Sakhawy, Structural Behaviour of Ferrocement Roof Elements [M.Sc thesis], Menoufia University, Shebin El-Kom, Egypt, 2007.
- [7] N.R. Husein, V.C. Agarwal, A. Rawat, An experimental study on using lightweight web sandwich panel as a floor and a wall, *Int. J. Innovative Technol. Exploring Eng. (IJITEE)* 3 (2278–3075) (2013).
- [8] Y.B.I. Shaheen, E.A. Eltehawy, Structural behaviour of ferrocement channels slabs for low cost housing, *Challenge J. Concr. Res. Lett.* 8 (2) (2017) 48–64.
- [9] P. Desayi, V. Reddy, Strength and behaviour of light-weight ferrocement in tension, in: Proceedings, Second International Symposium on Ferrocement, International Ferrocement Information Centre, Asian Institute of Technology, Bangkok, Thailand, 1985, pp. 61–73.
- [10] D.G. Gaidhankar, M.S. Kulkarni, A.R. Jaiswal, Ferrocement Composite Beams Under Flexure, *IRJET* 04 (10) (2017) 117–124.
- [11] Anuchat Leeanansakiri, Phaiboon Panyakapo, Anat Ruangrassamee, "Seismic capacity of masonry infilled RC frame strengthening with expanded metal ferrocement, *Eng. Struct.* 159 (2018) 110–127.
- [12] O. Lalaj, Y. Yardim, S. Yilmaz, Recent perspectives for ferrocement, *Res. Eng. Struct. Mater.* (1) (2015) 11–23, <https://doi.org/10.17515/resm2015.04st0123>.
- [13] Faris Matalkah, Harsha Bharadwaj, Parviz Soroushian, Wu. Wenda, Areej Almalkawi, Anagi M. Balachandra, Amirpasha Peyvandi, Development of sandwich composites for building construction with locally available materials, *Constr. Build. Mater. J.* 147 (2017) 380–387.
- [14] I.G. Shaaban, Expanded Wire Fabric Permanent Formwork for Improving Flexural Behaviour of Reinforced Concrete Beams, in: Proceedings of the International Congress: Challenges of Concrete Construction, Dundee, Scotland, UK, September 2002, 2002, pp. 59–70, <https://doi.org/10.1680/cmicc.31746.0006>.
- [15] T.A. Abdel, Development of Permanent Formwork for Beams Using Ferrocement Laminates (Ph.D thesis), Menoufia University, Shebin El-Kom, Egypt, 2006.
- [16] M. Abdul Kadir, M. Jaafar, Ferrocement in situ permanent formwork, *J. Ferrocement* 23 (2) (1993) 125–133.
- [17] G. Mays, R. Barnes, Ferrocement permanent formwork as protection to reinforced concrete, *J. Ferrocement* 25 (4) (1995) 331–345.
- [18] M. Abdul Kadir, A. Abdul Samad, Z. Che Muda, A. Ali, Flexural behavior of composite beam with ferrocement permanent formwork, *J. Ferrocement* 27 (1997) 209–214.
- [19] E.H. Fahmy, Y.B.I. Shaheen, A.M. Abdelnaby, M.N.A. Zeid, Applying the ferrocement concept in construction of concrete beams incorporating reinforced mortar permanent forms, *Int. J. Concr. Struct. Mater.* 8 (1) (2014) 83–97, <https://doi.org/10.1007/s40069-013-0062-z>.
- [20] P. Desayi, S.A. El-Kholy, Lightweight fibre-reinforced ferrocement in tension, *Cem. Concr. Compos.* 13 (1991) 37–48.
- [21] M.A. El-Wafa, K. Fukuzawa, Various sizes of wire mesh reinforcement effect on tensile behavior of ferrocement composite plates, in: Proceedings of the 10th International Summer Symposium Organized by Japan Society of Civil Engineers (JSCE), Tokyo, Japan, 2008, pp. 193–196.
- [22] M.A. El-Wafa, K. Fukuzawa, Characteristics of ferrocement thin composite elements using various reinforcement meshes in flexure, *J. Reinf. Plast. Compos.* (2010), <https://doi.org/10.1177/0731684410377814>.
- [23] N.A. Memon, S.R. Sumadi, M. Ramli, Strength and behaviour of lightweight ferrocement, *Malaysian J. Civ. Eng.* 18 (2) (2006) 99–108.
- [24] M.A. Mansur, P. Paramasivam, Ferrocement under combined bending and axial loads, *Int. J. Concr. Struct. Mater.* 8 (1) (1985) 151–158.
- [25] E.L. Elsayed, Structural Behaviour of light weight ferrocement composite concrete beams, an MSc Thesis submitted to Faculty of Engineering, Benha University, pp. 138, 2014.
- [26] ACI 549.1R-93 & ACI 549-1R-88, A. C. I. Guide for the Design Construction, and Repair of Ferrocement, ACI Committee 549.1R-93; ACI 549-1R-88 and 1R-93, 1997.
- [27] ASTM C/150-07 (2007) Standard Specification for Portland Cement.
- [28] ASTM C 494/C494M (2005) Standard Specification for Chemical Admixtures for Concrete.
- [29] Y.S. Korany, Repairing Reinforced Concrete Columns Using Ferrocement Laminates, MSc thesis submitted to The American University in Cairo, Egypt, 1996.
- [30] J. Sridhar, R. Malathy, R.K. Sangeetha, Flexural Strengthening of Reinforced Concrete Beams using Ferrocement Laminates with Partial Replacement of Fine Aggregate by Steel Slag, *J. Eng. Technol.* 4 (2) (2014) 123–126, <https://doi.org/10.4103/0976-8580.141205>.
- [31] G.J. Al-Sulaimani, I.A. Basunbul, E.A. Mousselhy, Shear Behavior of Ferrocement Box Beams, *Cem. Concr. Compos.* 13 (1991) 29–36.
- [32] S. Wasim, N. Razvi, Review on ferrocement, *Int. J. Innovations Eng. Technol. (IJJET)* 6 (2) (2015) 338–340.
- [33] I.G. Shaaban, O. Seoud, Experimental behaviour of full-scale exterior beam-column space joints retrofitted by ferrocement layers under cyclic loading, *Case Stud. Constr. Mater.* 8 (2018) 61–78, <https://doi.org/10.1016/j.cscm.2017.11.002>.
- [34] M.A. El-Wafa, K. Fukuzawa, Flexural behavior of lightweight ferrocement sandwich composite beams, *J. Sci. Technol.* 15 (1) (2010) 3–16.
- [35] V. Greepala, P. Nimityongskul, Structural integrity of ferrocement panels exposed to fire, *Cem. Concr. Compos.* 30 (2008) 419–430.
- [36] S. Wang, A.E. Naaman, V.C. Li, Bending response of hybrid ferrocement plates with meshes and fibers, *J. Ferrocement* 34 (1) (2004).